

İDOL

ALUMİNIYUM SYSTEMS



KATALOG ZA STAKLENE OGRADE
GLASS RAILING CATALOG

WWW.IDOLALUMINIYUM.COM

ĪDOL ALŪMĪNYUM

121070

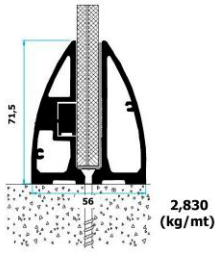

BAZA ZA STAKLENU OGRADU LR 70

121071

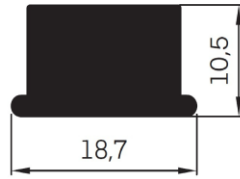

LR 70 ZATEGAC STAKLA

121080

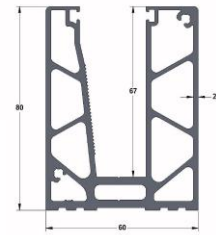

BAZA ZA STAKLENA OGRADA LR 80

121100

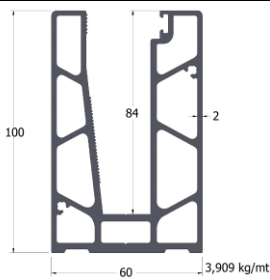

BAZA ZA STAKLENA OGRADA SĪSTEM LR 100

121110

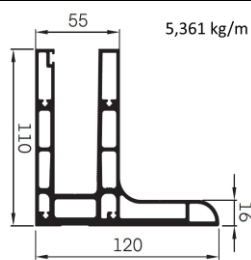

BAZA ZA STAKLENU OGRADU BL 110

121115

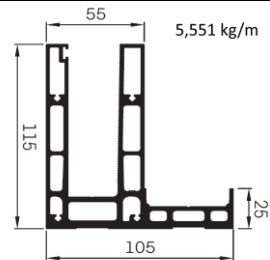

BAZA ZA STAKLENU OGRADU BL 115

121115

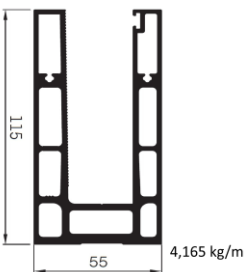

BAZA ZA STAKLENU OGRADU LR 115

121125

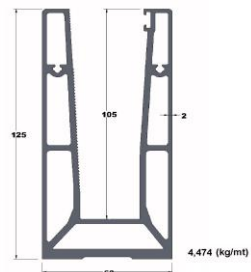

BAZA ZA STAKLENA OGRADA SĪSTEM LR 125

121170

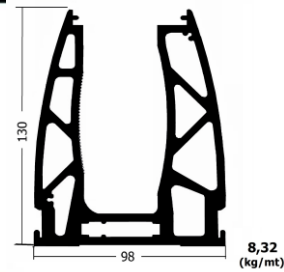

BAZA ZA STAKLO OGRADE C70

121171

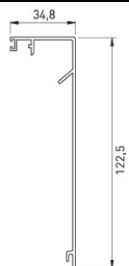

POKLOPAC ZA BAZU C70

122020

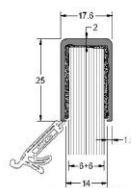

RUKOHVAT ZA STAKLENU OGRADU 17X25

122021

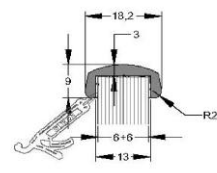

RAVNĪ RUKOHVAT ZA STAKLENU OGRADU 6+6

122022

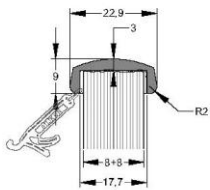

0,206 kg/mt

**RAVNI RUKOHVAT ZA STAKLENU
OGRADU 8+8**

122023

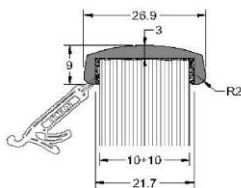

0,234 kg/mt

**RAVNI RUKOHVAT ZA STAKLENU
OGRADU 10+10**

122030

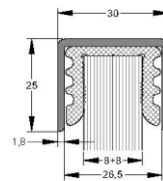

0,382 kg/mt

**RUKOHVAT ZA STAKLENU
OGRADU 30X25**

122031

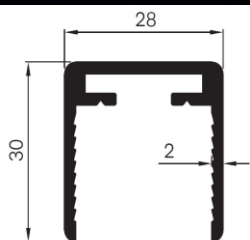

0,528 kg/m

**RUKOHVAT ZA STAKLENU
OGRADU L30**

122040

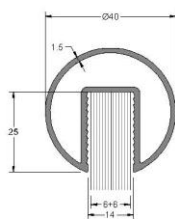

0,729 kg/mt

**RUKOHVAT ZA STAKLENU
OGRADU F40 14MM**

122041

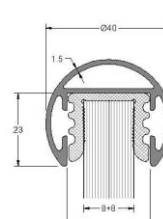

0,621 kg/mt

**RUKOHVAT ZA STAKLENU
OGRADU F40 26 MM**

122050

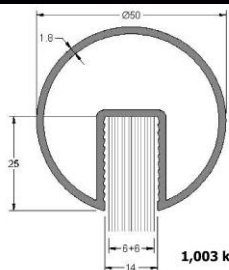

1,003 kg/mt

**RUKOHVAT ZA STAKLENE
OGRADU F50 14MM**

122051

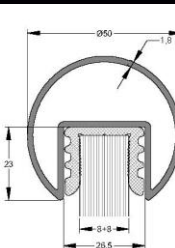

0,946 kg/mt

**RUKOHVAT ZA STAKLENU
OGRADU F50**

122052

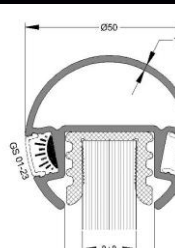

0,960 kg/mt

**RUKOHVAT ZA STAKLENU
OGRADU F50 SA LED SİJALICAMA**

122060

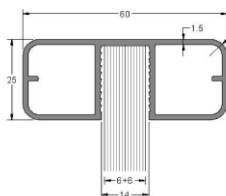

0,892 kg/mt

**RUKOHVAT ZA STAKLENU
OGRADU 60X25 14MM**

122061

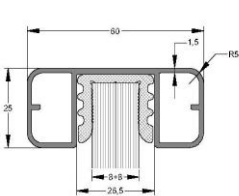

0,781 kg/mt

**RUKOHVAT ZA STAKLENU
OGRADU 60-25**

122080

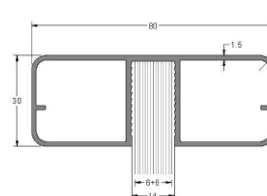

1,092 kg/mt

**RUKOHVAT ZA STAKLENU
OGRADU 80X30 14MM**

122081

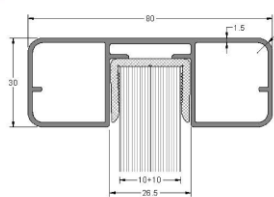

1,076 kg/mt

RUKOHVAT ZA STAKLENU
OGRADU 80X30 26,5MM

122082

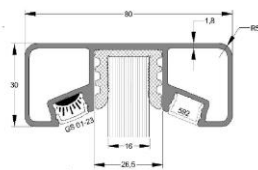

1,289 kg/mt

RUKOHVAT ZA STAKLENU
OGRADU SA LED SÍJALÍCE 80-30

122085

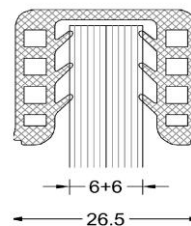

GUMA ZA RUKOHVAT U 12 MM

122086

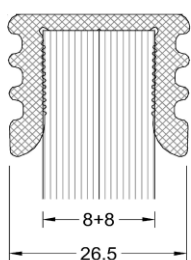

GUMA ZA RUKOHVAT U 16 MM

122087

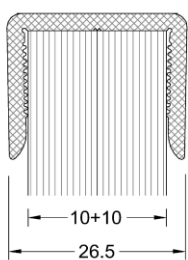

GUMA ZA RUKOHVAT U 20 MM

122170



SET ZA ZATEZANJE STAKLA C70

122171



ZAVRSNÍ POKLOPAC ZA C70

122173

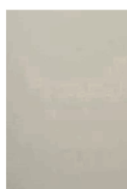

ZAVRSNÍ POKLOPAC ZA LR 80

122174



ZAVRSNÍ POKLOPAC ZA LR 100

122176



ZAVRSNÍ POKLOPAC ZA LR 125

123178

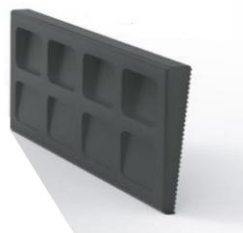

PLASTÍCNA KAJLA 16MM LR 80-LR
100

123179

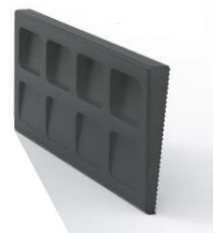

PLASTÍCNA KAJLA 12MM LR 80-LR
100

123181



PLASTİCNA KAJLA 12MM LR 116-LR125

123182

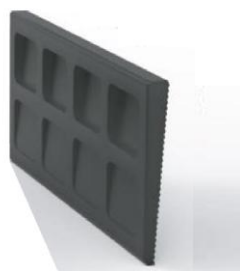

PLASTİCNA KAJLA 20MM LR 125

123183



PLASTİCNA KAJLA 12MM LR 125

123185

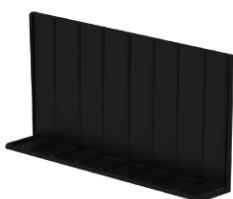

PLASTİCNA L KAJLA LR 116

123186



PLASTİCNA L KAJLA LR 125

123193

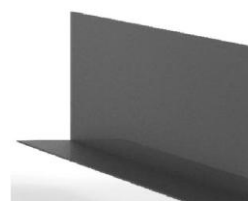

GUMA ZA STAKLO L 1,5 MM

123194



GUMA ZA STAKLO ZA C70 SİSTEM

123195



GUMA BOCNA ZA STAKLENU OGRADU

123196



GUMA BOCNA ZA STAKLENU OGRADU

123198



GUMA BOCNA ZA STAKLENU OGRADU

123199

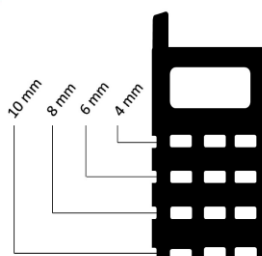

GUMA BOCNA UNİVERZALNA ZA STAKLENU OGRADU

223001



CEP ZA U PROFİL 30-25

223002



**ZAVRSNA FLANSA ZA 30X25
PROFİL**

223005



UGAO ZA 30-25 PROFİL POD 90

223006



UGAO ZA 30-25 PROFİL POD 135

225001



CEP ZA F50 SA KANALOM

225002



ZAVRSNA FLANSA ZA F50

225003



FLANSA ZA F50 SA TRİ RUPA

225004



**POKLOPAC ZA FLANSU F50 SA TRİ
RUPE**

225006

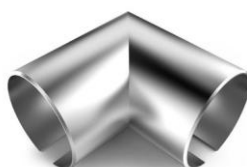

**UGAO ZA STAKLENU OGRADU 90
F50**

225007

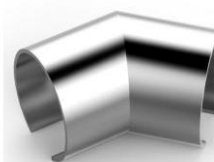

**UGAOA ZA STAKLENU OGRADU
135 F50**

226001



CEP ZA 60-25 PROFİL

226002

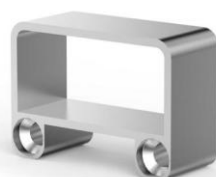

ZAVRSNA FLANSA ZA PROFİL 60-25

226005



UGAO ZA 60-25 PROFİL POD 90

226006



UGAO ZA 60-25 PROFİL 135

226008



PRSTEN ZA 60-25 PROFİL

228001



CEP ZA 80-30 PROFİL

228002



ZAVRSNA FLANSA ZA PROFİL 80-30

228005



UGAO ZA 80-30 PROFİL POD 90

228006



UGAO ZA 80-30 PROFİL POD 135

228008

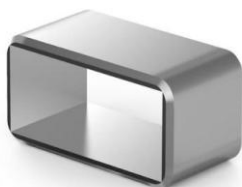

PRSTEN ZA 80-30 PROFİL

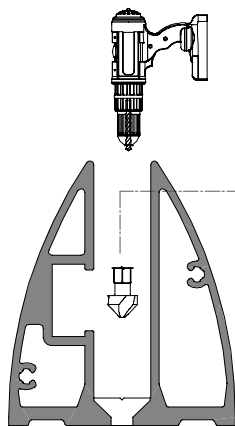

izbusiti rupe sa burgijom $\varnothing 12$ mm ,
posle napraviti konus.
Drill holes with a $\varnothing 12$ mm drill.
Then open countersunk.

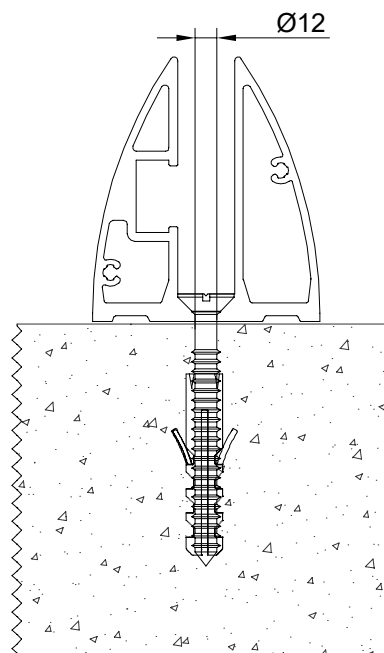
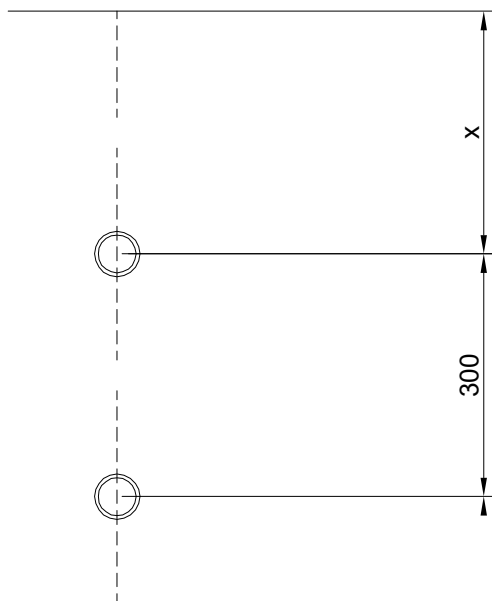

Otvarati rupe na razmahu od 300 mm .
Drill holes at 300 mm intervals.
Staklo ne sme da se naslanja na strafove!
Screw head should not touch the glazing!

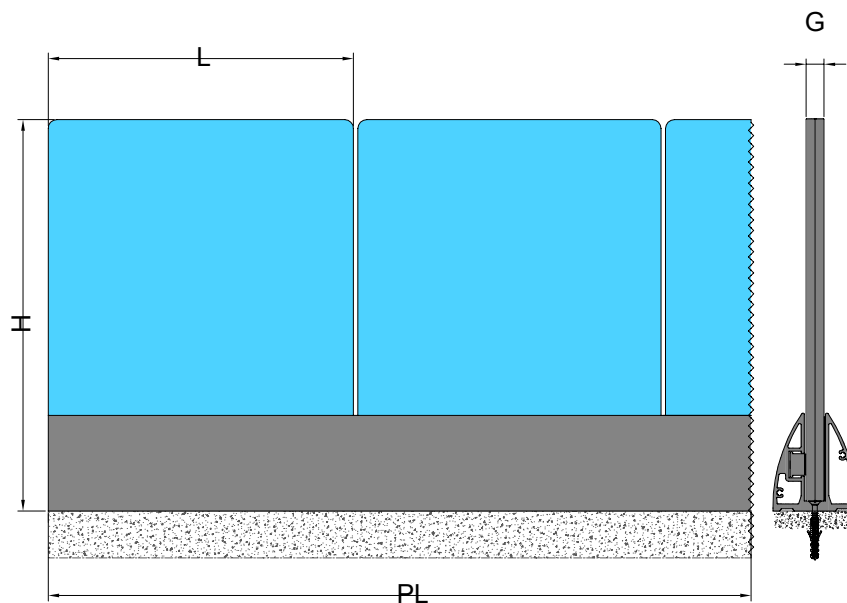

(H)maks. Visina Stakla	(G) Debljina Stakla	(L)maks. Velicina stakala
600 mm	5+5+0,76 mm	1000 mm
600 mm	6+6+0,76 mm	1000 mm

PL maks : 6000 mm

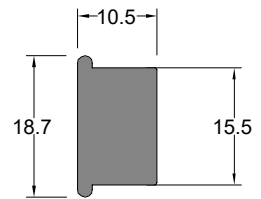
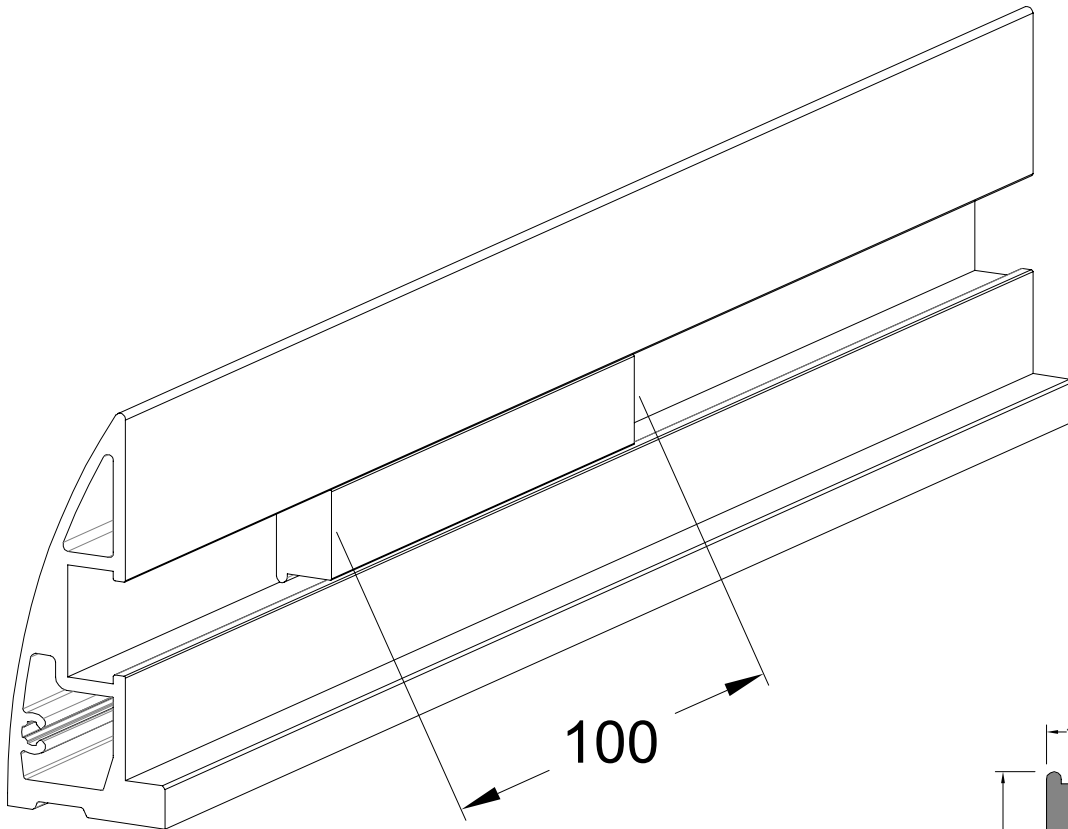
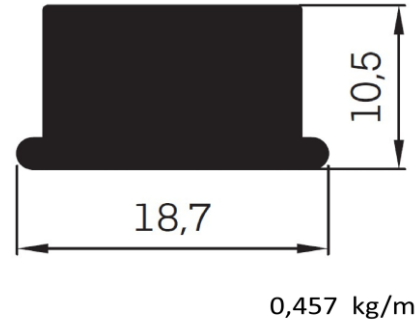
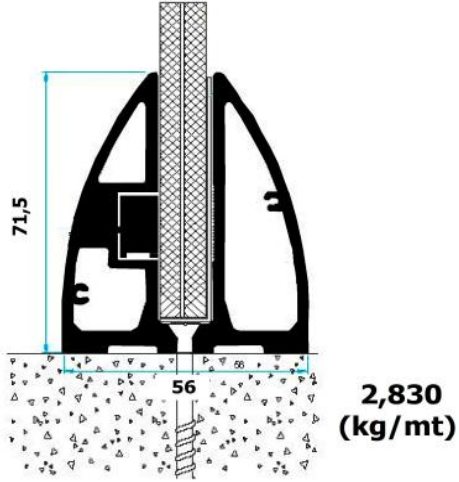

Profil adaptor	Sifra	(kg/mt)
ADAPTER PROFILE	Profile Code	Weight
	121071	0,458

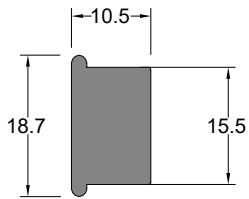
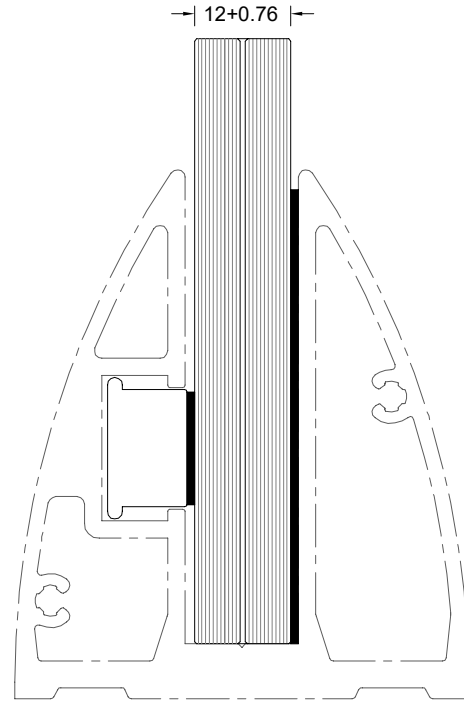
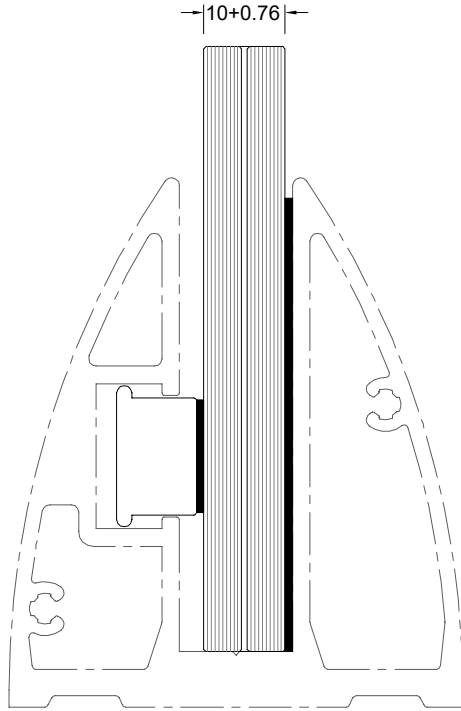

Profil adapter	Sifra	(kg/mt)
ADAPTER PROFILE	Profile Code	Weight
	121071	0,458

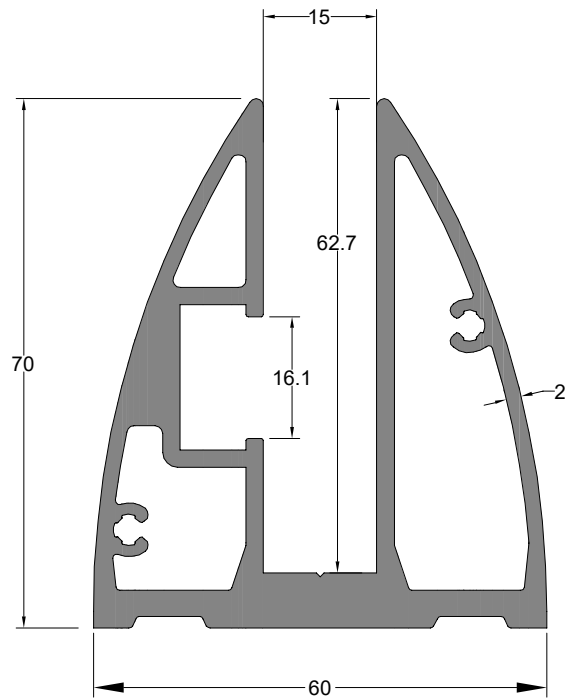

Baza profil LR 70	Sifra	(kg/mt)
GLAZING HANDRAIL PROFILE	Profile Code	Weight
	121070	2,767

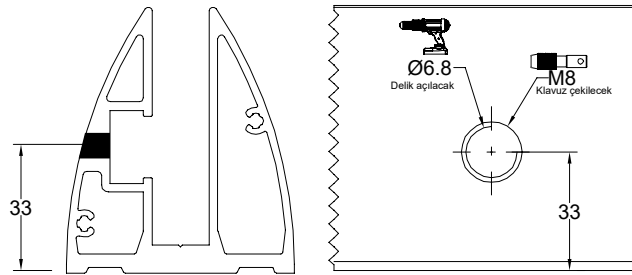
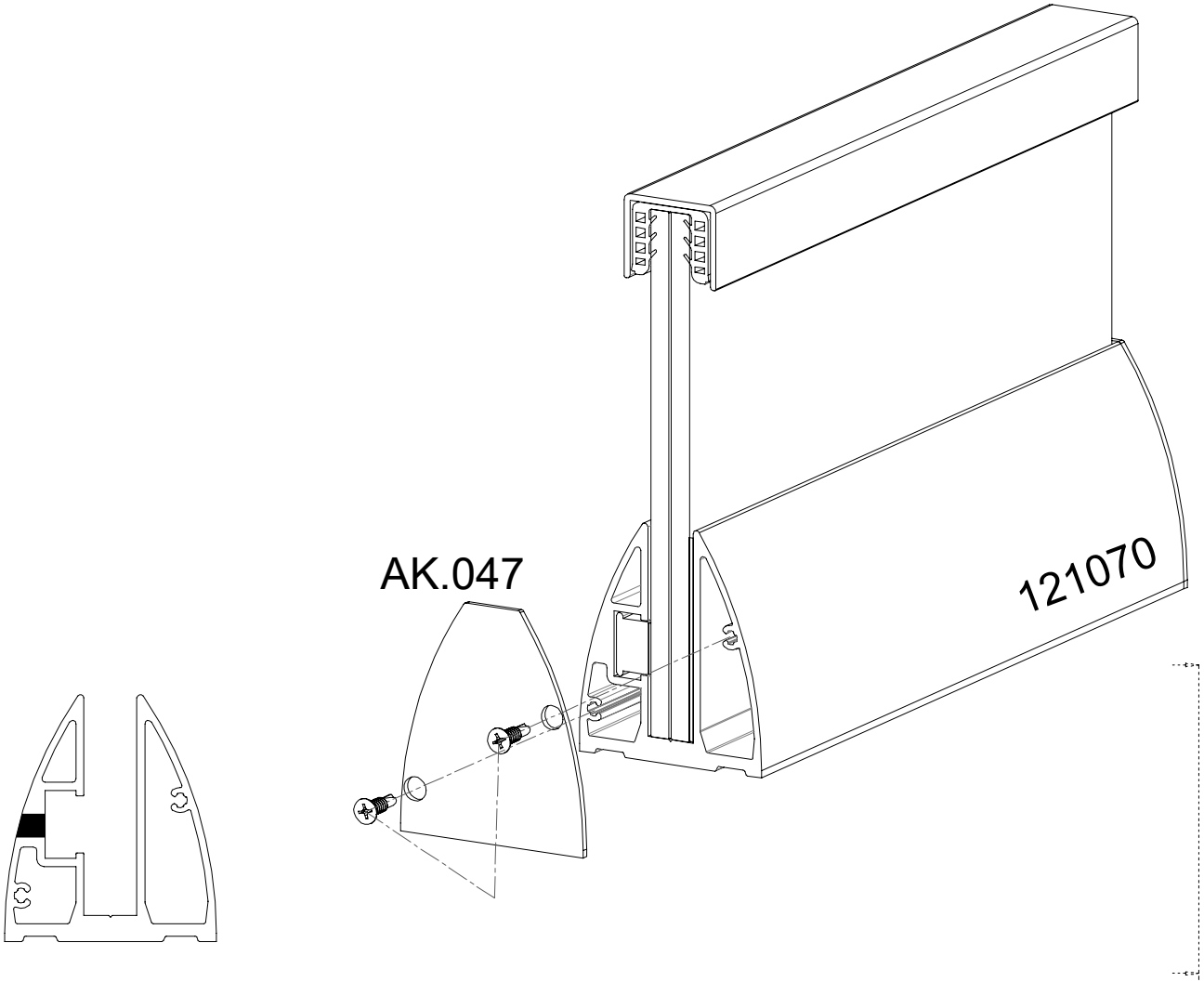

RUKOHVATI za STAKLENE OGRADE

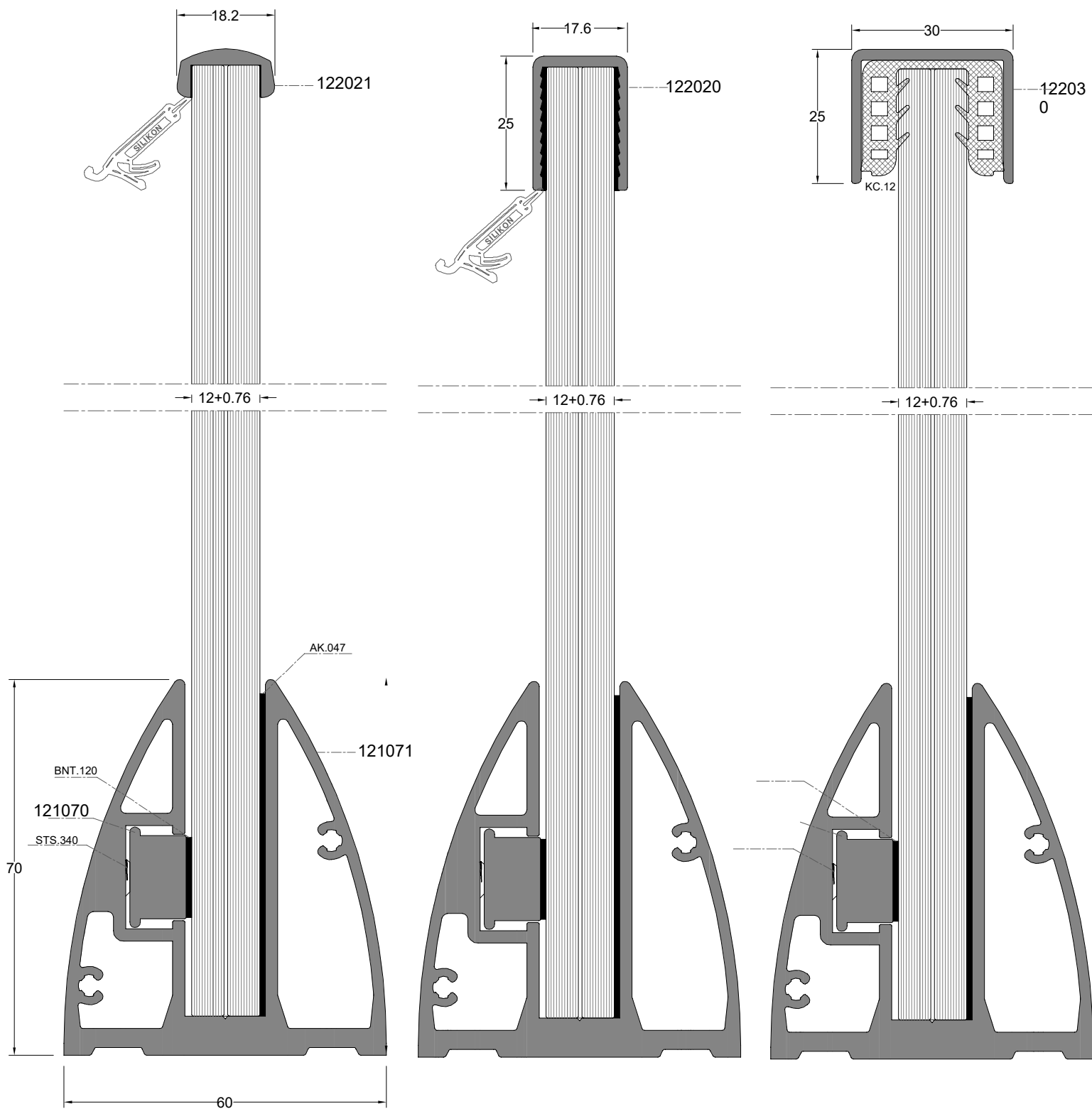

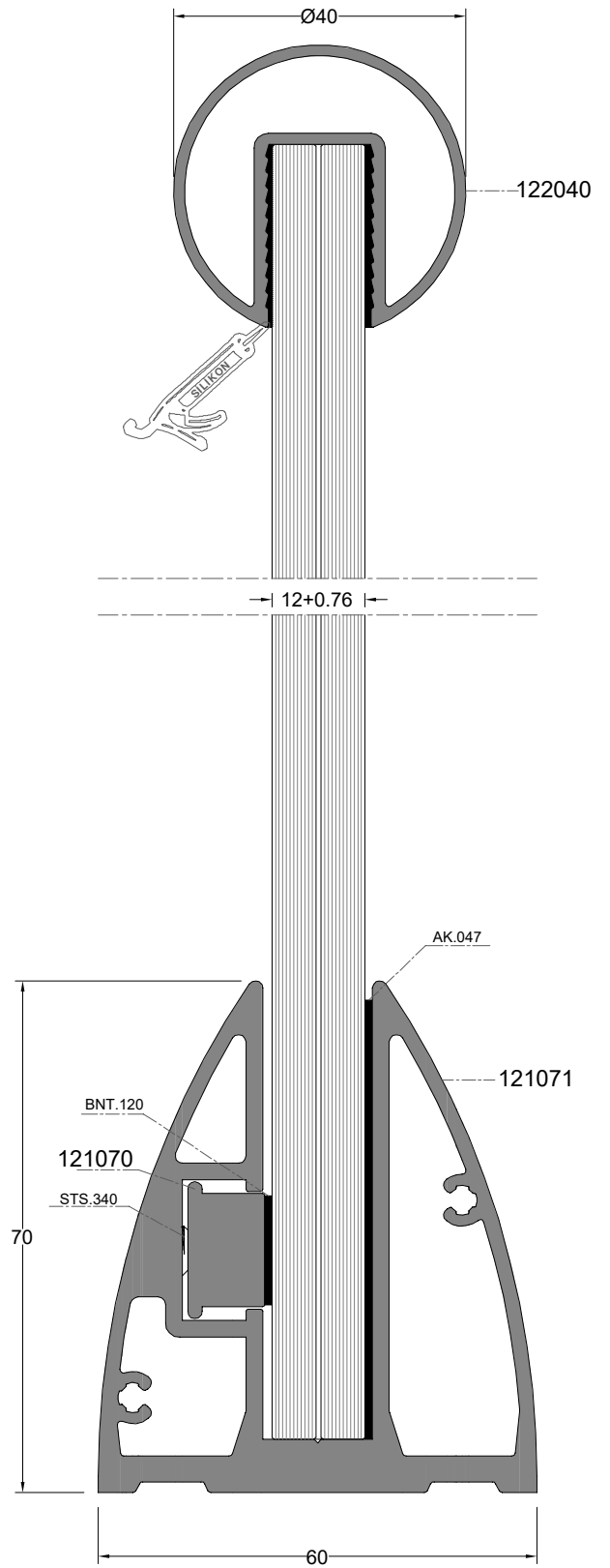
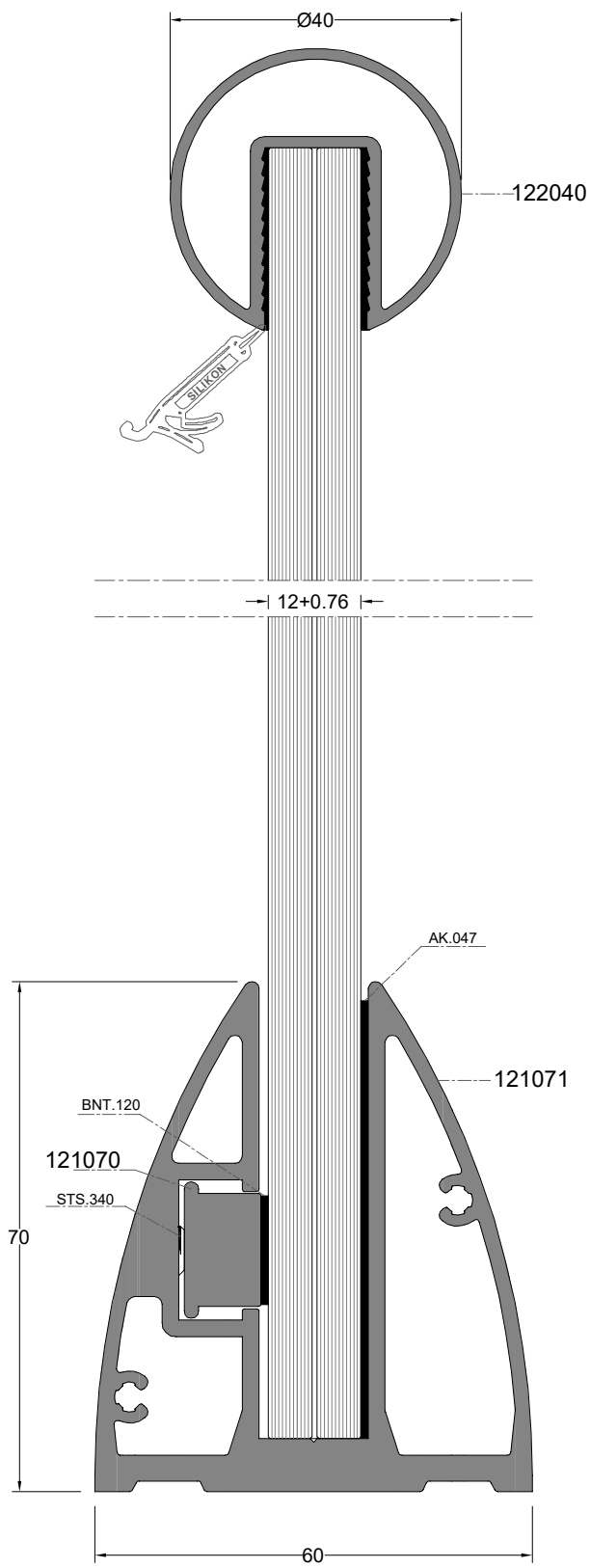

RUKOHVATİ za STAKLENE OGRADE

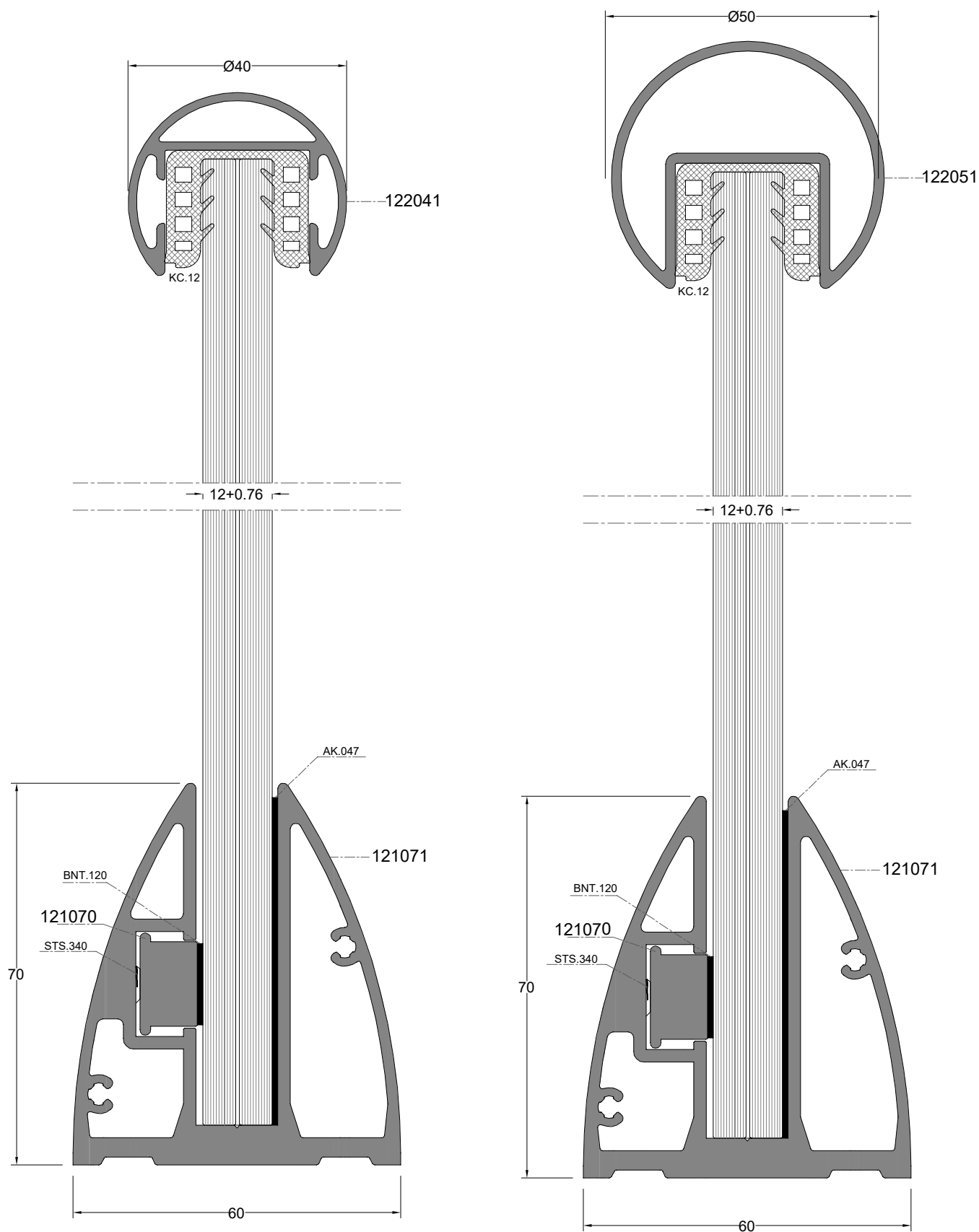

RUKOHVATİ za STAKLENE OGRADE

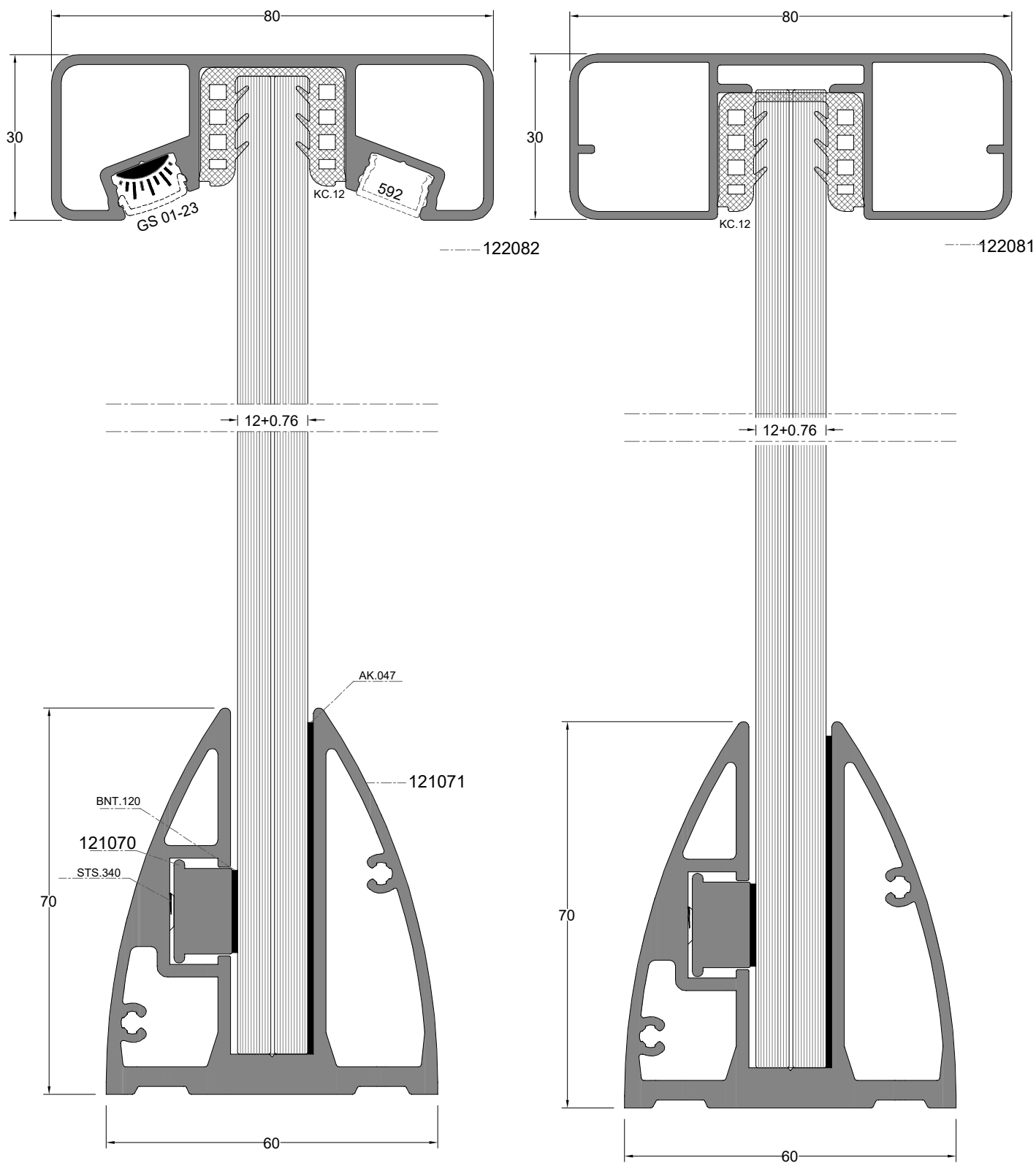



LR 80 STAKLENA OGRADA LR 80 Handrail System

TEHNIČKE KARAKTERISTIKE / TECHNICAL PROPERTIES

Baza profil sirina / Base profile width	60mm
Baza profil visina / Base profile height	80mm
Unutrasna dubina za staklo / Glazing depth in profile	67mm
Maksimalna visina stakla / Max. Glazing railing height	1200mm
Maksimalna širina stakla / Max. glazing railing width	1200mm

OPCIJE APLIKACIJE / APPLICATION OPTIONS

Debljina stakla / Glazing Thickness	12mm	16mm
Test pri udarcu / Impact test	ima	ima
Test pri guranja / Push test	ima	ima



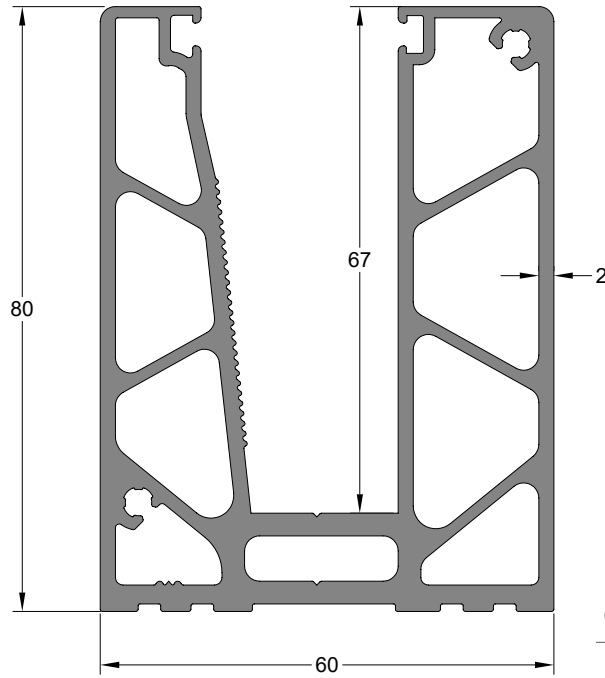

Baza Profil	Sifra Profile Code	(kg/mt) Weight
GLAZING GROOVE PROFILE	121080	3,194

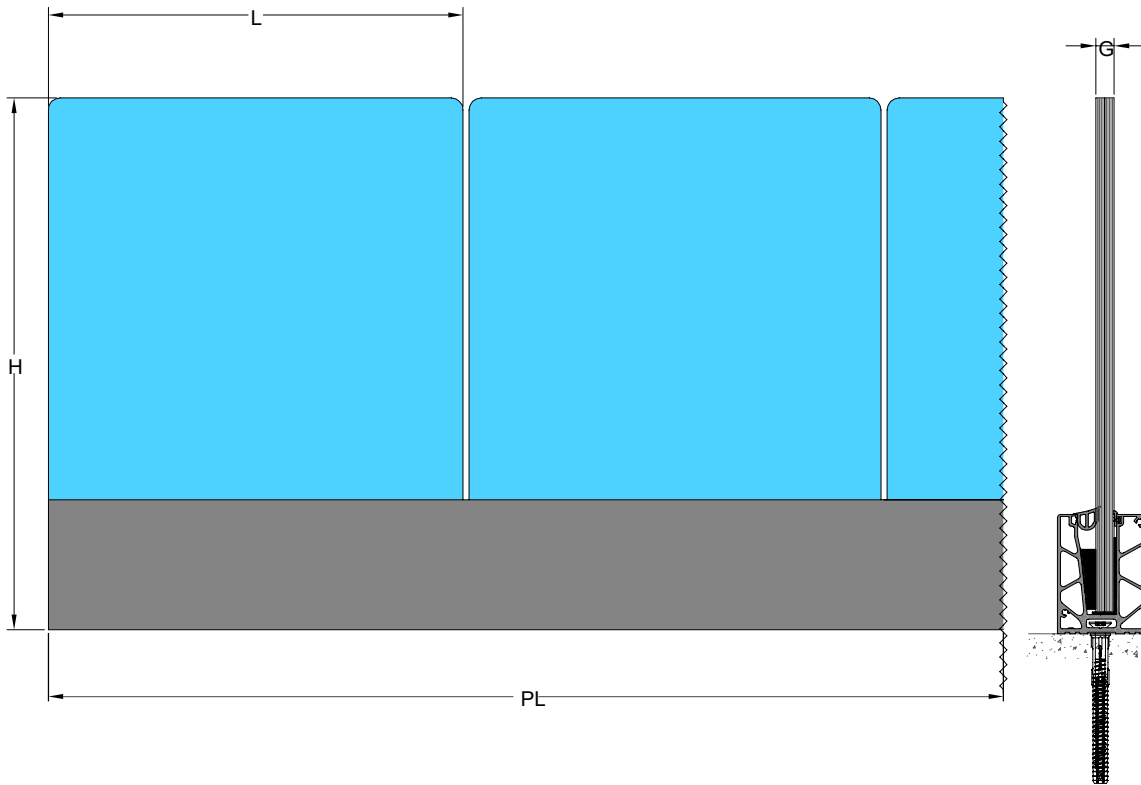

(H)maks. Visina Stakla	(G) Debljina stakla	(L)maks. Duzina Stakla
800 mm	6+6 +1,52 mm	1200 mm
800 mm	8+8 +1,52 mm	1000 mm

PL maks : 7000 mm

İDOL ALÜMİNYUM

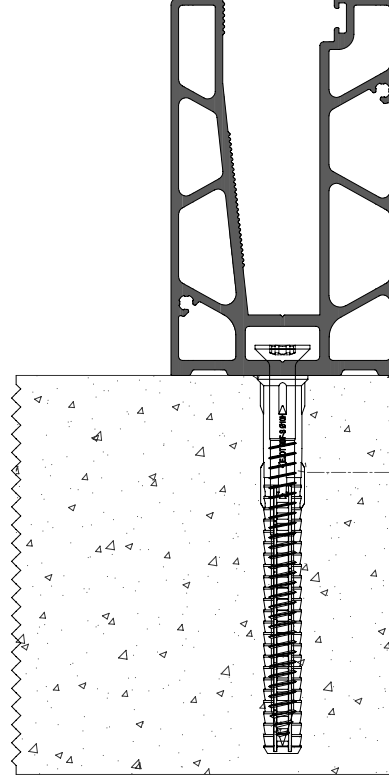
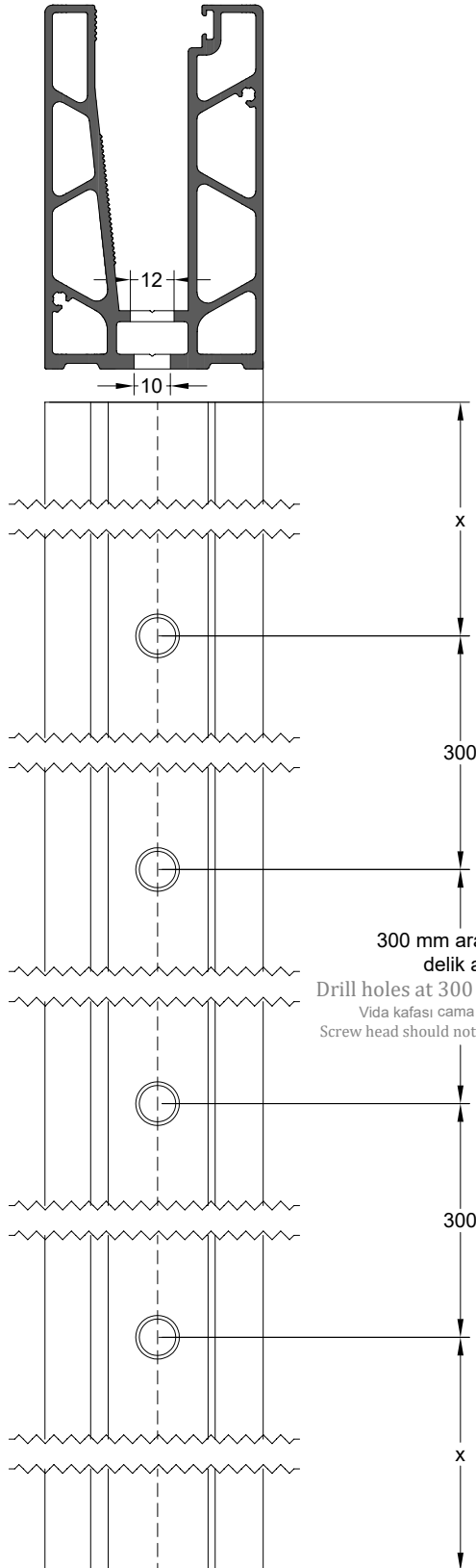
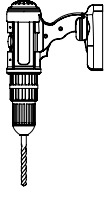

Aksesuar Kodu
Product Code
DBLE.10100

300 mm aralıklarla
delik aç.
Drill holes at 300 mm intervals.
Vida kafası cama değmemeli !
Screw head should not touch the glazing.

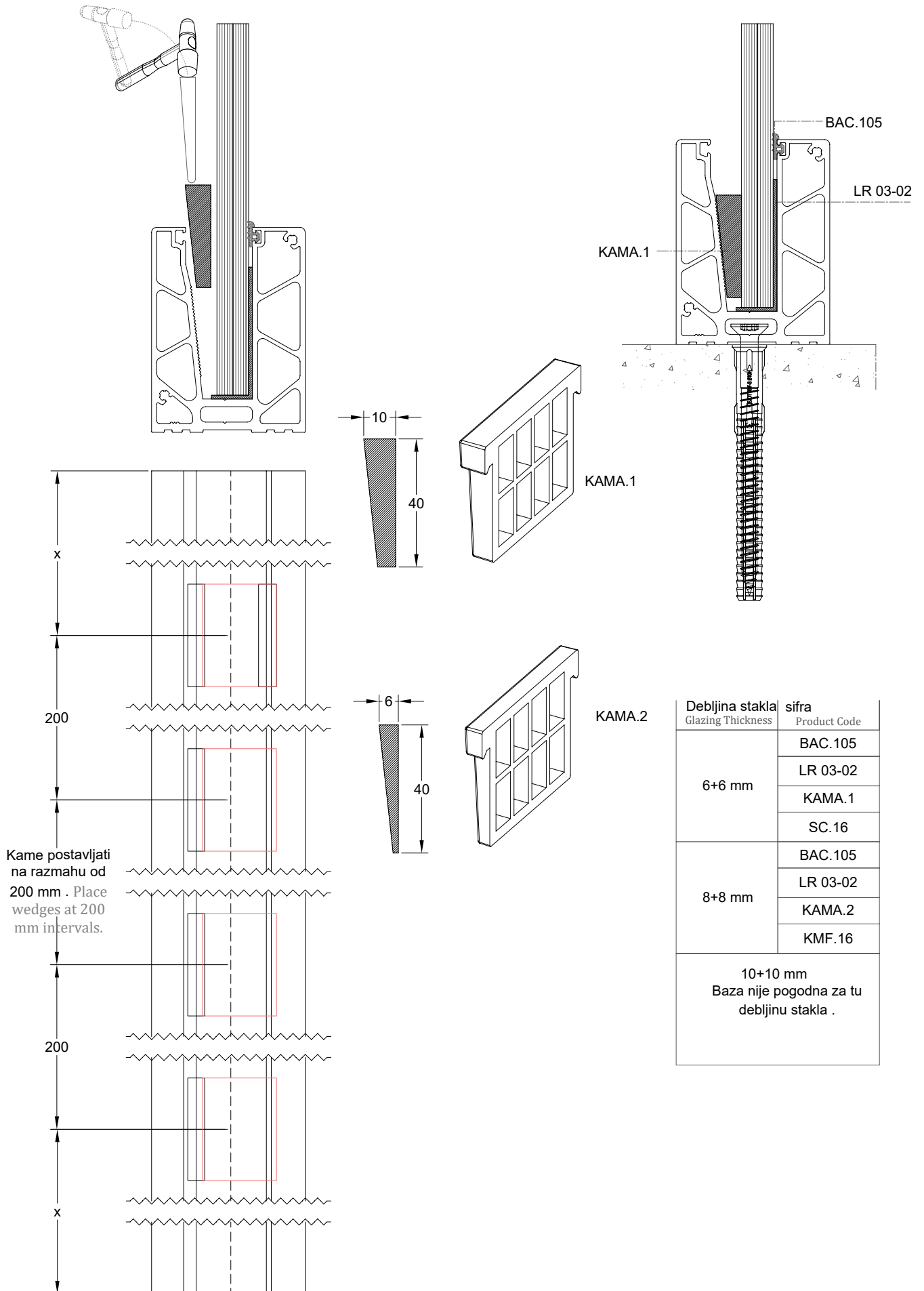



LR 100 STAKLENA OGRADA LR 100 Handrail System

TEHNIKE KARAKTERİSTİKE / TECHNICAL PROPERTIES

Baza profil sirina / Base profile width	60mm
Baza profil visina / Base profile height	100mm
Unutrasna dubina za staklo / Glazing depth in profile	84mm
Maksimalna visina stakla / Max. Glazing railing height	1200mm
Maksimalna Sirina stakla / Max. glazing railing width	1200mm

OPCIJE APLIKACIJE / APPLICATION OPTIONS

Debljina stakla / Glazing Thickness	12mm	16mm
Test pri udarca / Impact test	ima	ima
Test pri guranja / Push test	ima	ima



İDOL ALÜMİNYUM

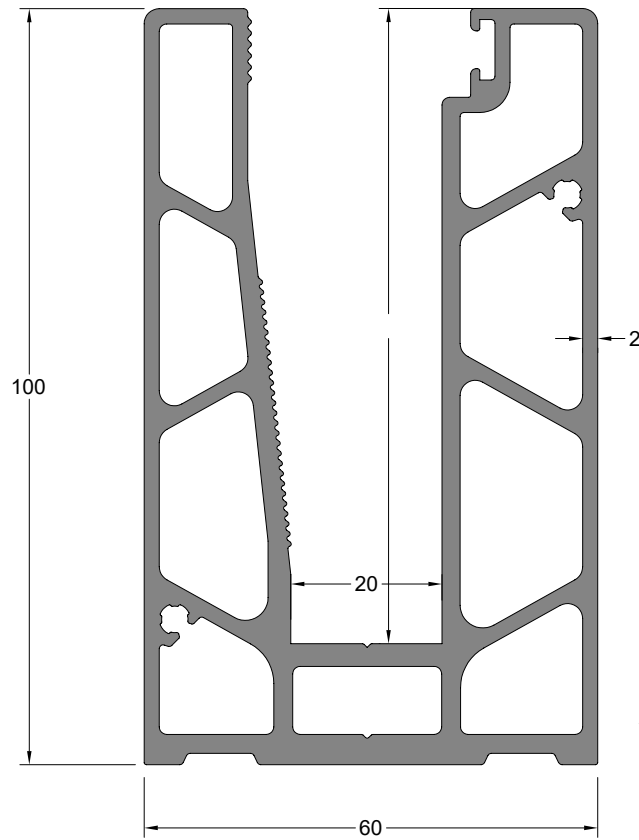

Baza Profil	Sifra Profile Code	(kg/mt) Weight
GLAZING GROOVE PROFILE	121100	3,909

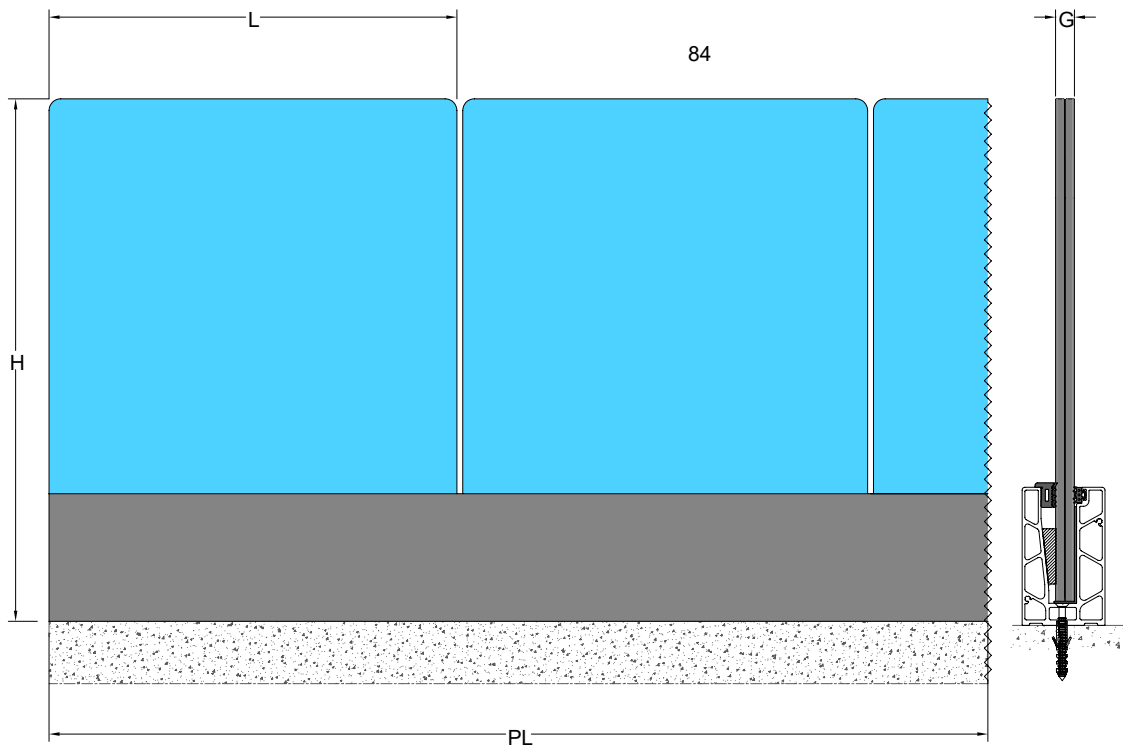

(H)maks. Visina stakla	(G) Debljina stakla	(L)maks. Duzina stakla
1000 mm	6+6 +1,52 mm	1500 mm
1000 mm	8+8 +1,52 mm	1200 mm

PL maks : 7000 mm

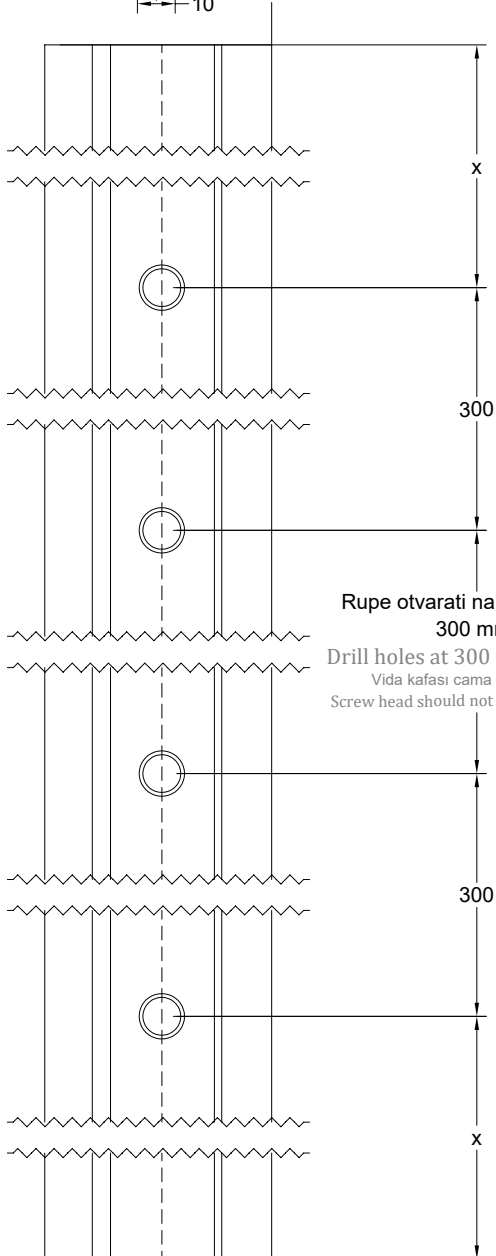
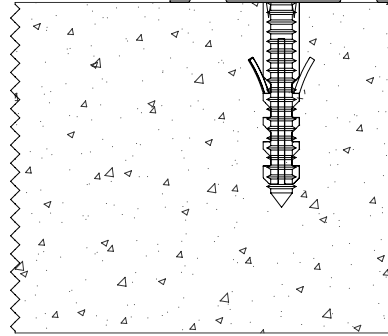
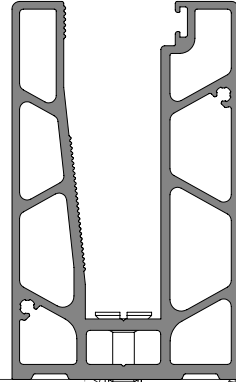
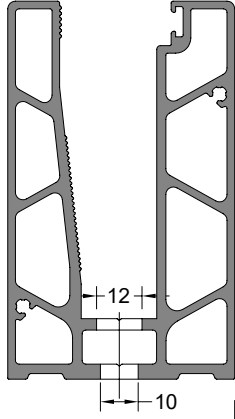
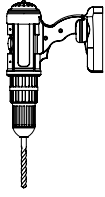

Rupe otvarati na razmahu od
300 mm.

Drill holes at 300 mm intervals.
Vida kafasi cama degnemeli !
Screw head should not touch the glazing.

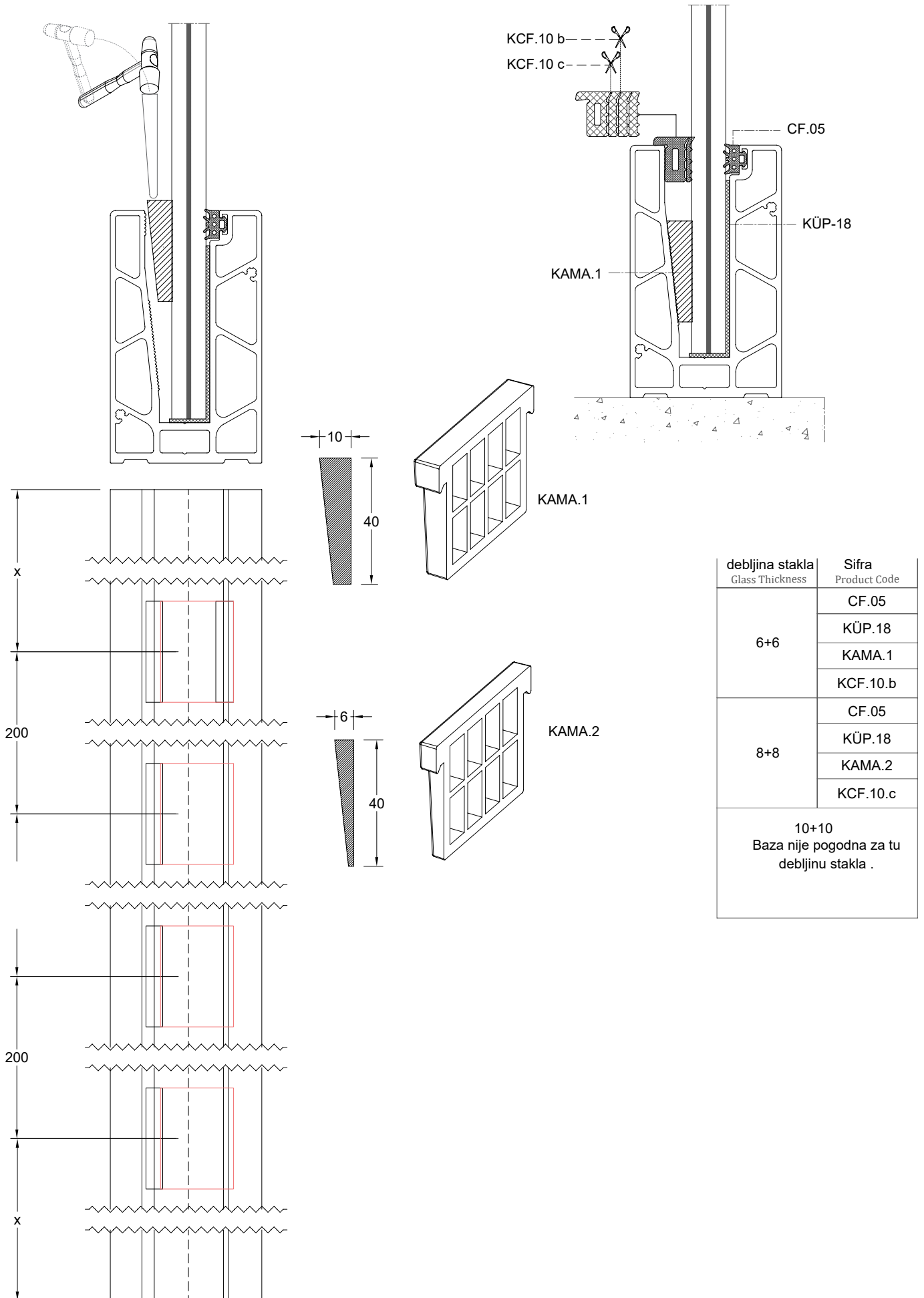

debljina stakla Glass Thickness	Sifra Product Code
6+6	CF.05
	KÜP.18
	KAMA.1
	KCF.10.b
8+8	CF.05
	KÜP.18
	KAMA.2
	KCF.10.c
10+10 Baza nije pogodna za tu debljinu stakla .	

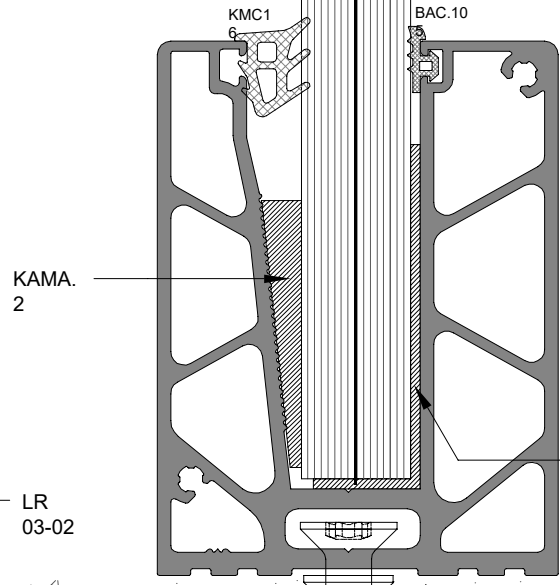
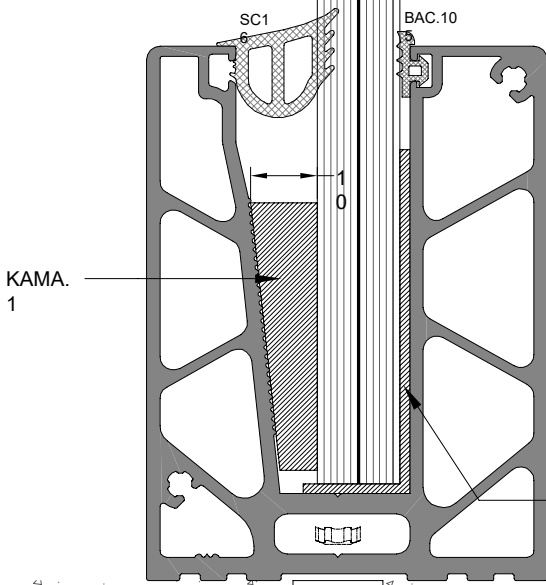
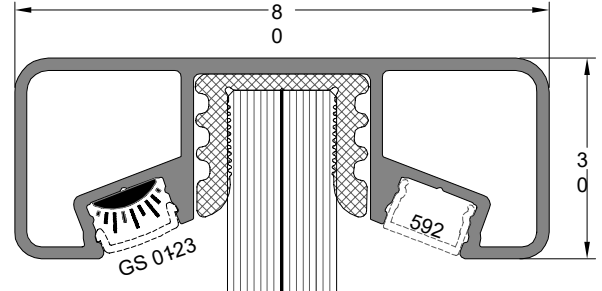
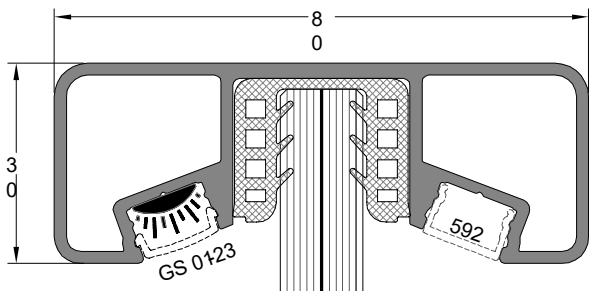

LR 03-02

LR 03-02

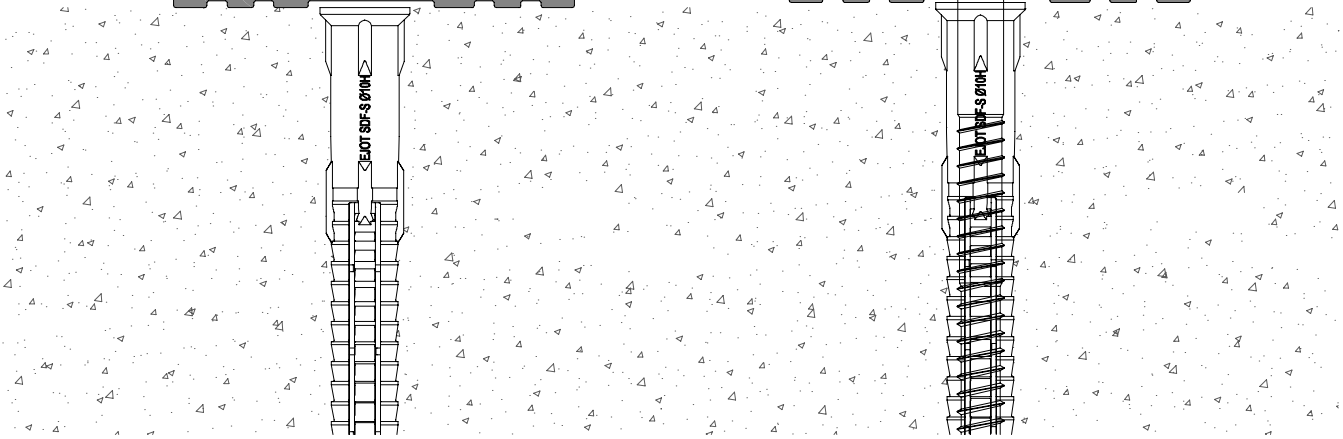



LR 125 STAKLENA OGRADA LR 125 Handrail System

TEHNIČKE KARAKTERISTIKE / TECHNICAL PROPERTIES

Baza profil sirina / Base profile width	60mm
Baza profil visina / Base profile height	125mm
Unutrasna dubina za staklo / Glazing depth in profile	105mm
Maksimalna visina stakla / Max. Glazing railing height	1200mm
Maksimalna širina stakla / Max. glazing railing width	1200mm

OPCIJE APLIKACIJE / APPLICATION OPTIONS

Debljina stakla / Glazing Thickness	12mm	16mm
Test pri udarcu / Impact test	ima	ima
Test pri guranju / Push test	ima	ima



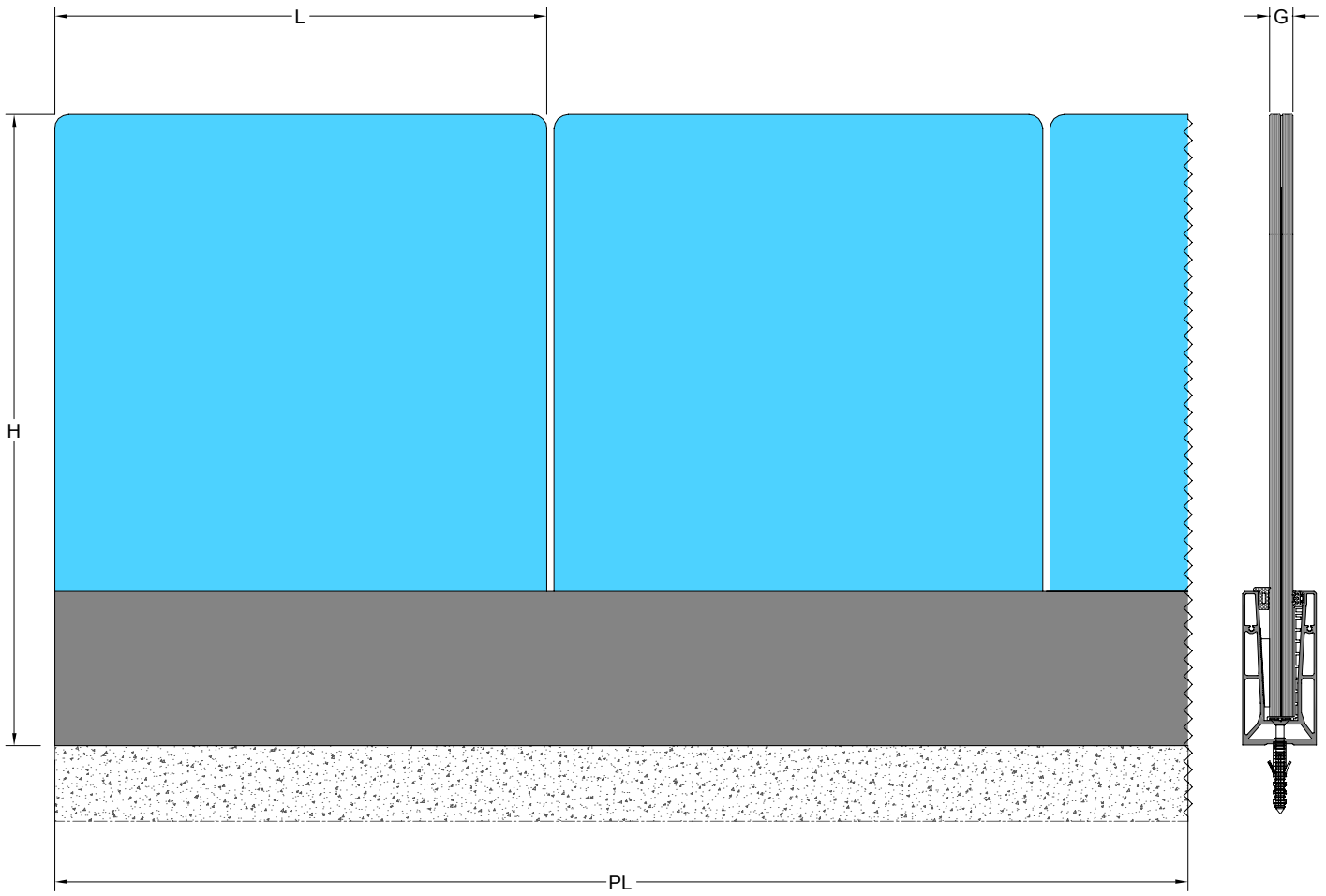

(H)maks. Visina stakla GLASS HEIGHT	(G) Debljina stakla GLASS THICKNESS	(L)maks. Duzina stakla IN-BETWEEN DISTANCE
1200 mm	6+6 +1,52 mm	1800 mm
1200 mm	8+8 +1,52 mm	1400 mm
1200 mm	10+10 +1,52 mm	1200 mm

PL maks : 7000 mm

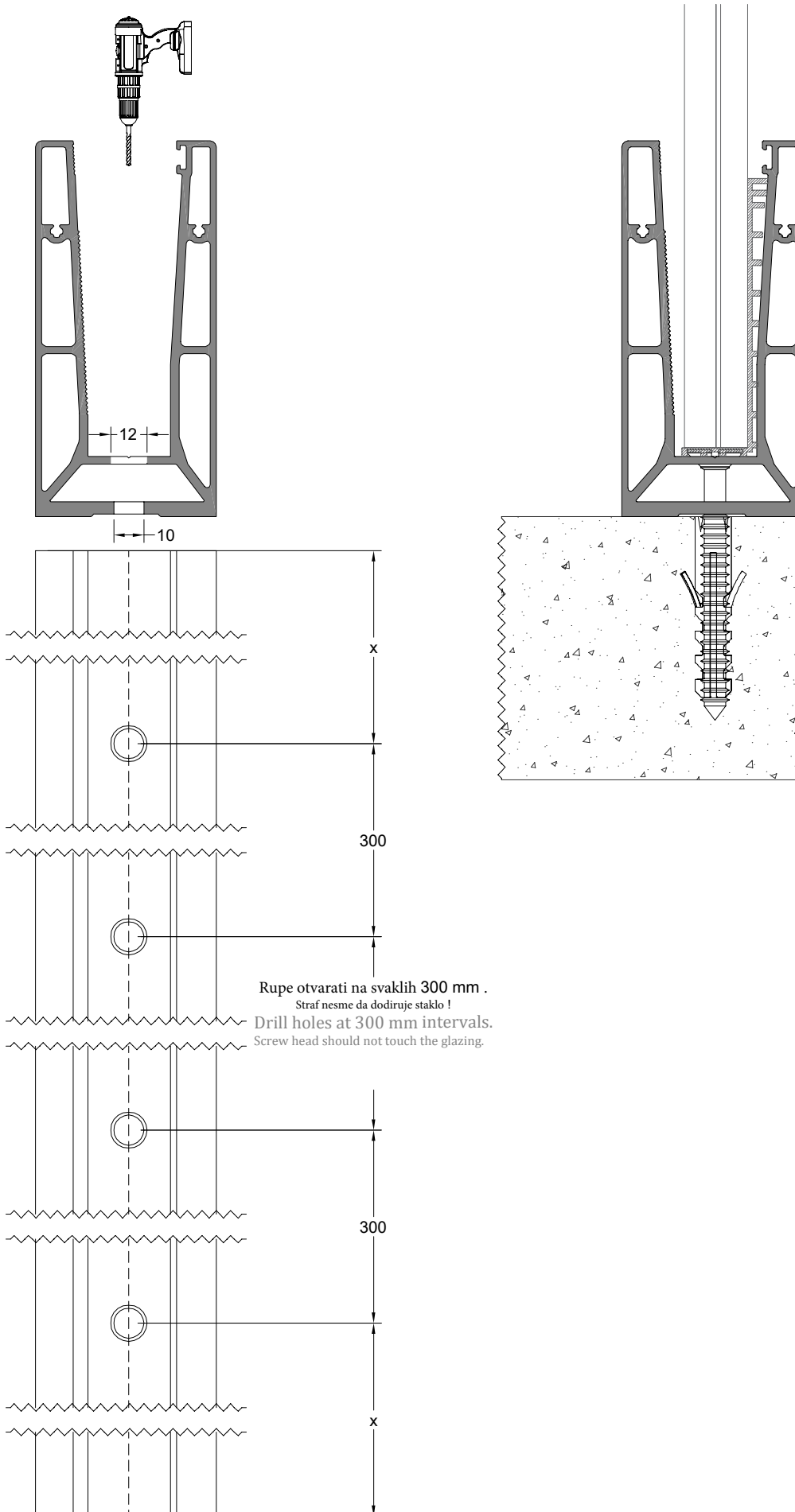

IDOL ALÜMİNYUM

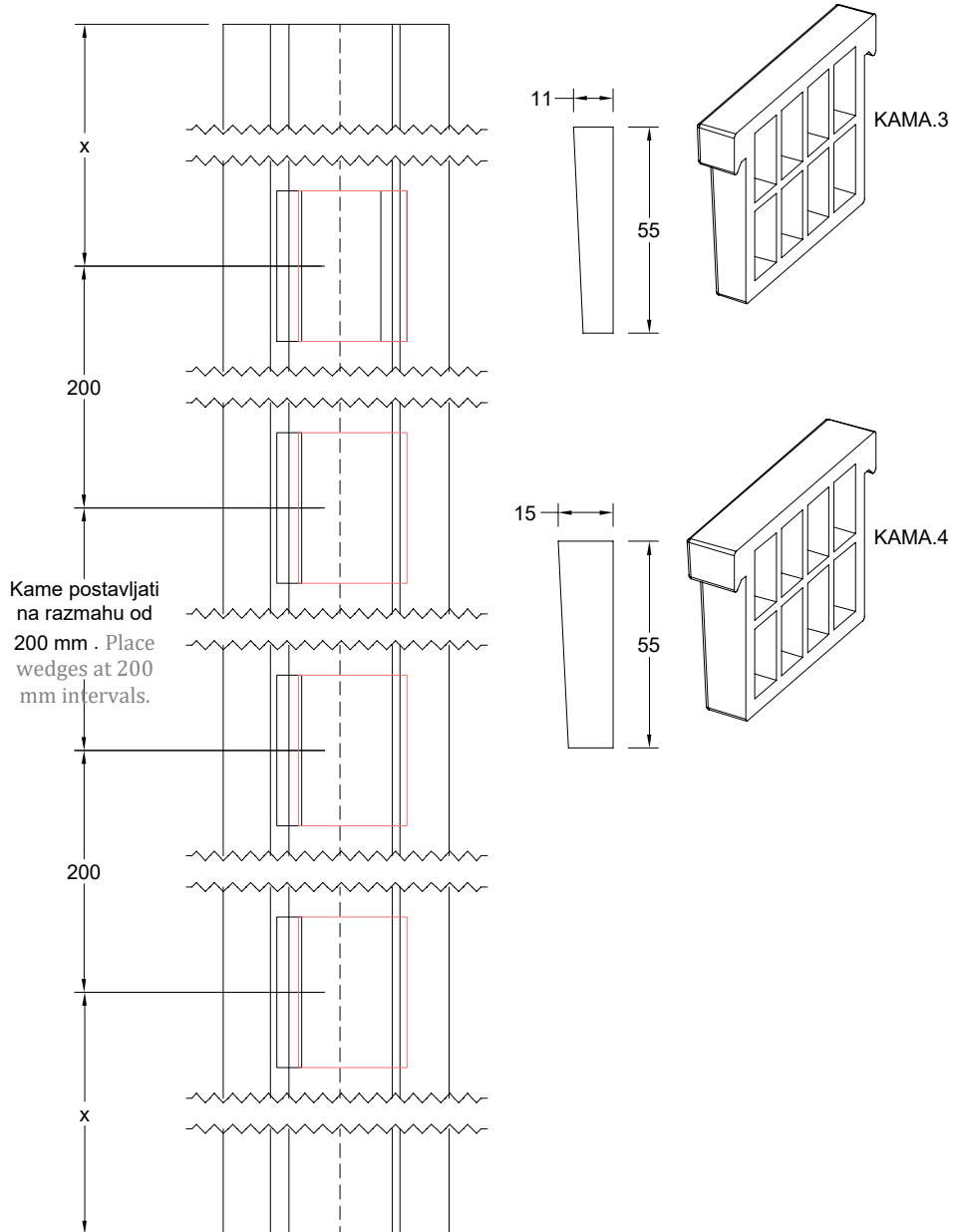
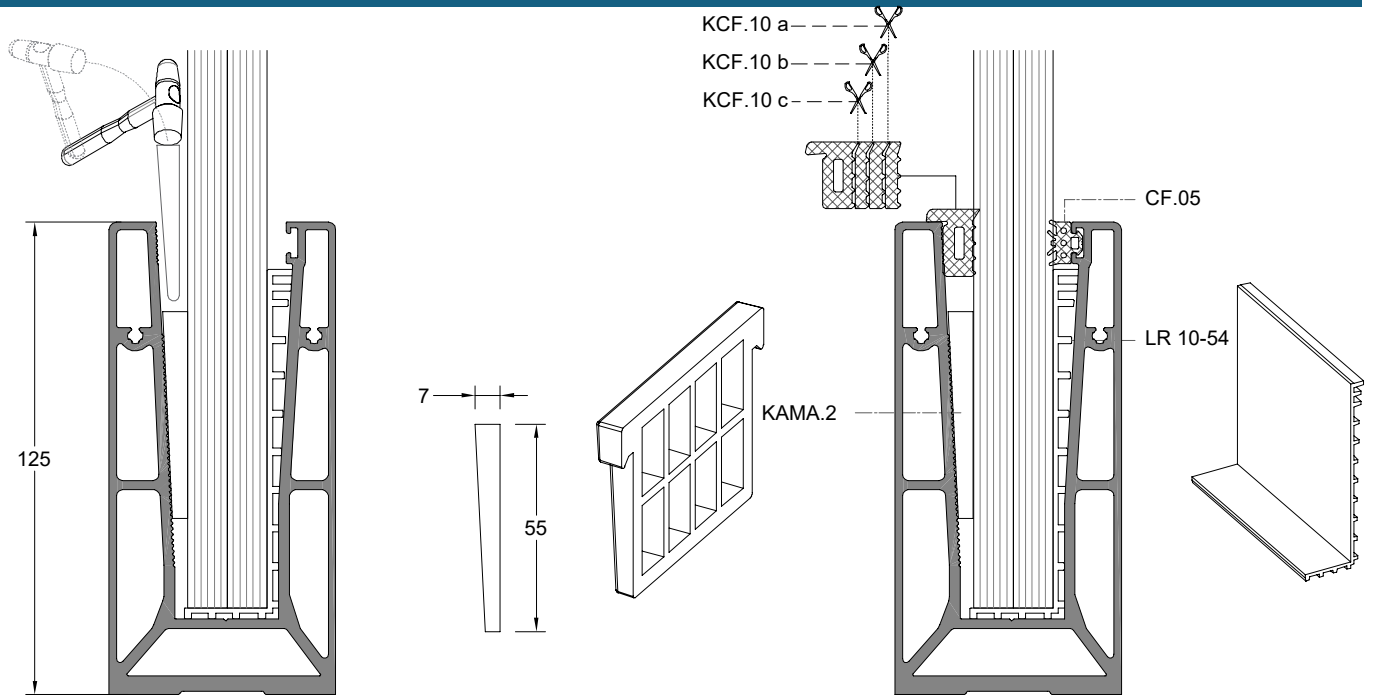

Debljina stakla Glass Thickness	Sifra Product Code
6+6	CF.05
	LR 10-54
	KCF.10 a
	KAMA.4
8+8	CF.05
	LR 10-54
	KCF.10 b
	KAMA.3
10+10	CF.05
	LR 10-54
	KCF.10 c
	KAMA.2

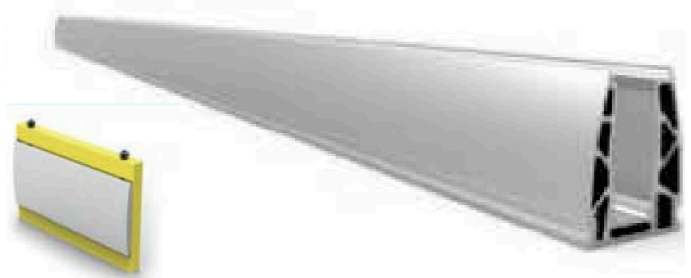
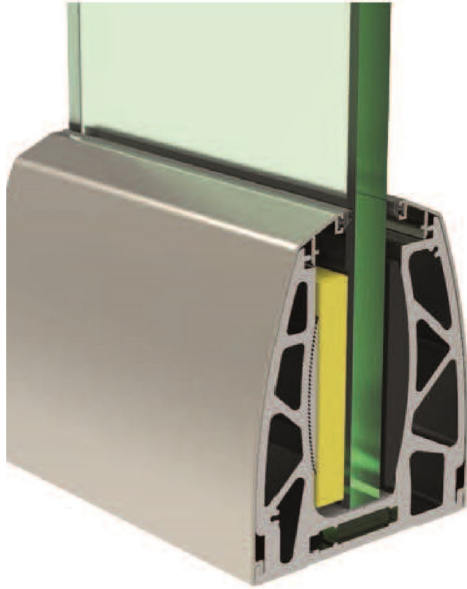

C70-MP16
Magic pack set for
8+8 mm Glass

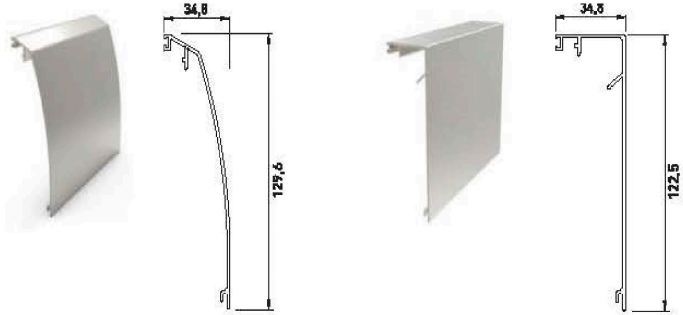

C 70

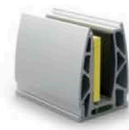

15 cm



30 cm

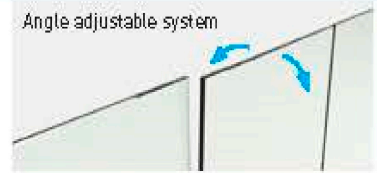
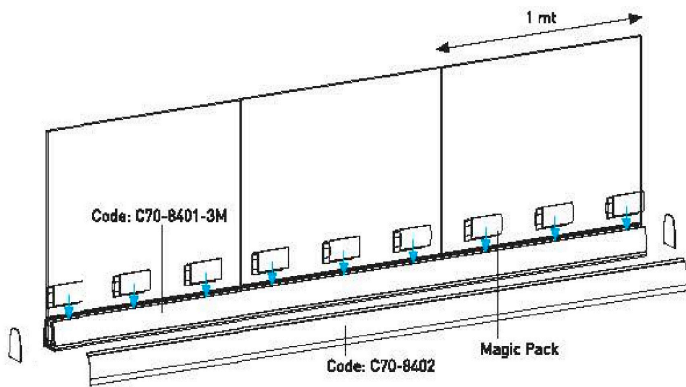

Angle adjustable system

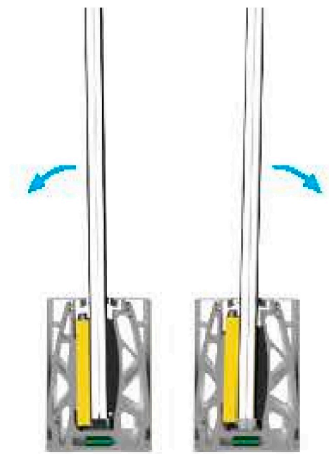
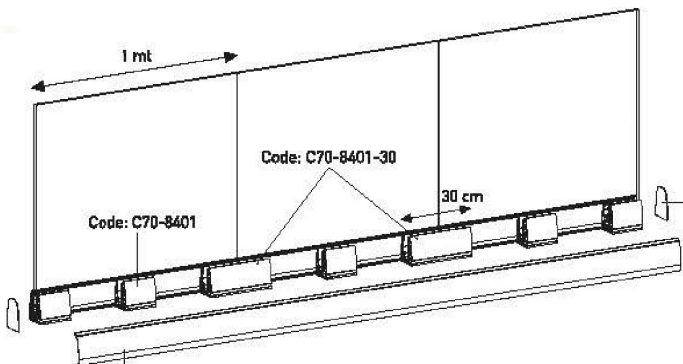

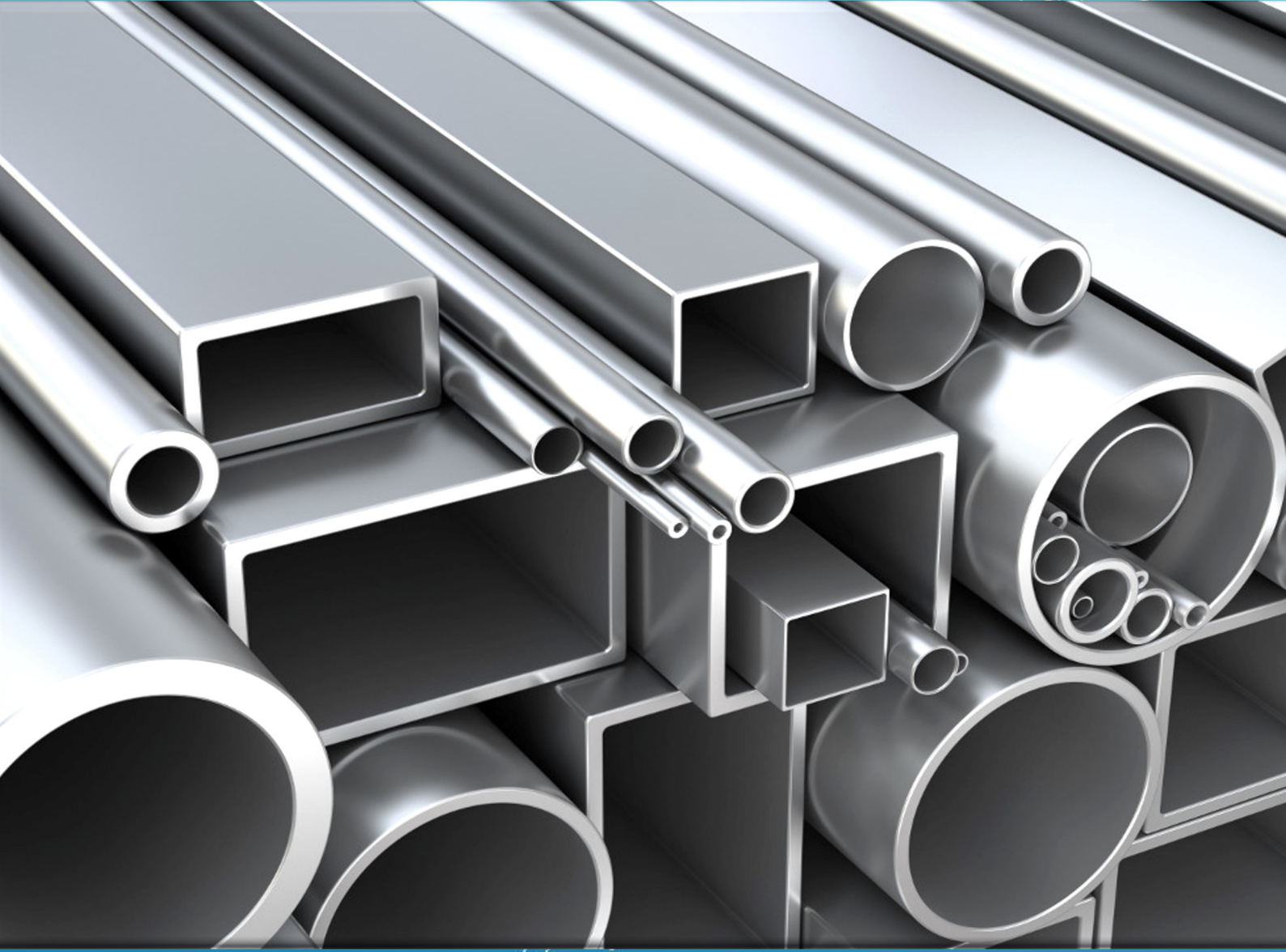

İDOL ALÜMİNYUM METAL DAN. İTH. İHR. SAN. TİC. LTD. ŞTİ.

Fevzi Çakmak Mah. Mustafa Kemal Cad.No: 8/A 34899 Pendik İstanbul

Telefon : (+90) 216 379 15 48

Faks : (+90) 216 379 15 49

Gsm : (+90) 532 223 57 56

Gsm : (+90) 535 690 33 48

E-mail: office@idolaluminijum.com